

FRONT VIEW
SCALE 1 : 10

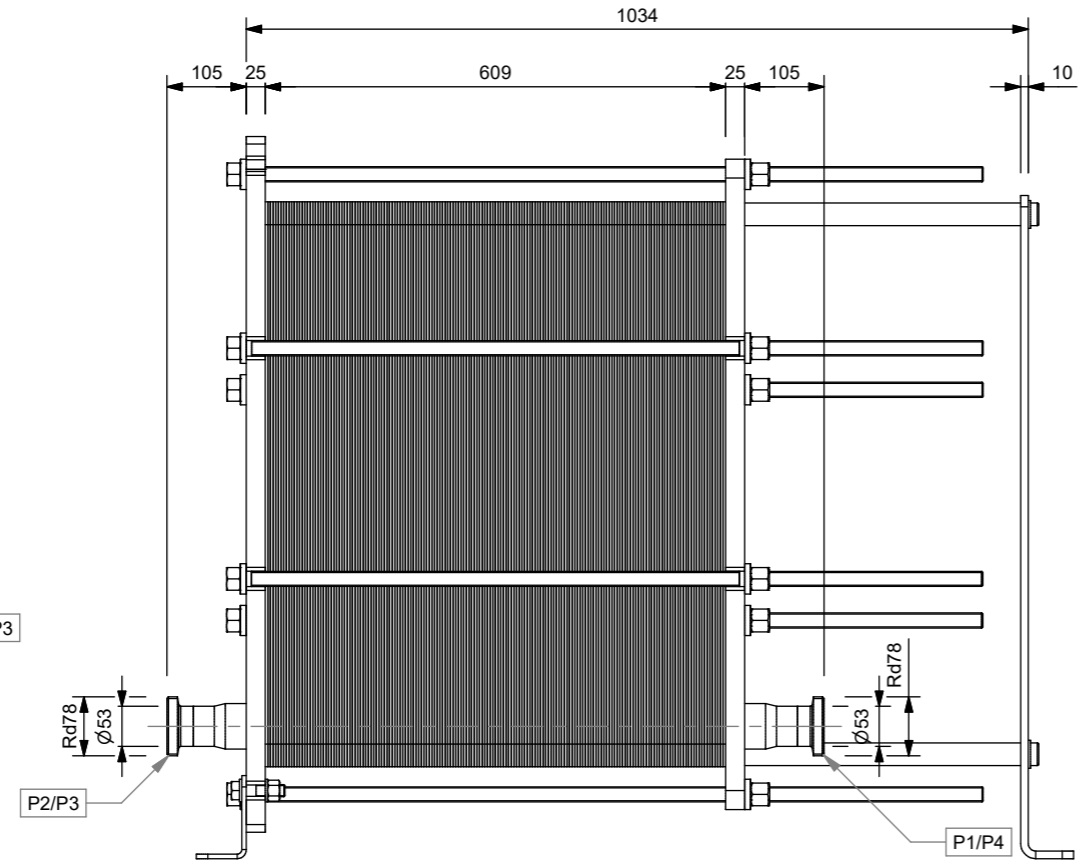

RIGHT VIEW
SCALE 1 : 10

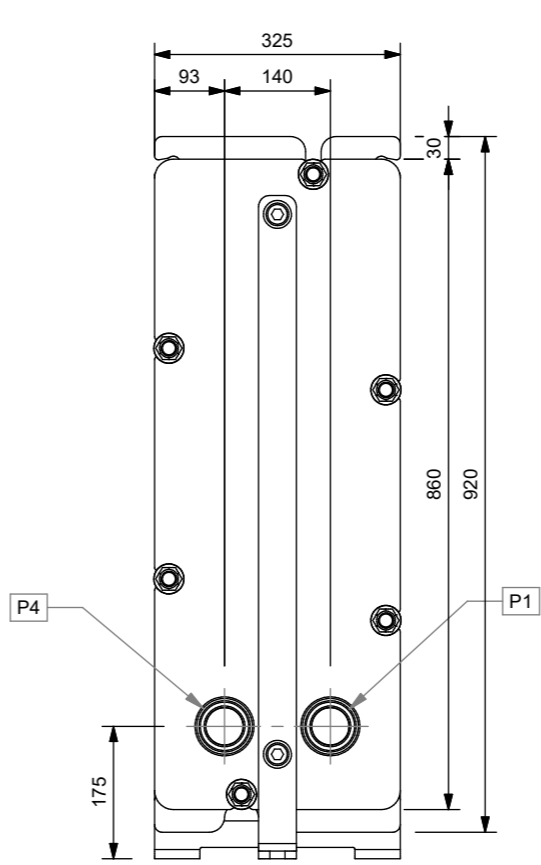

BACK VIEW
SCALE 1 : 10

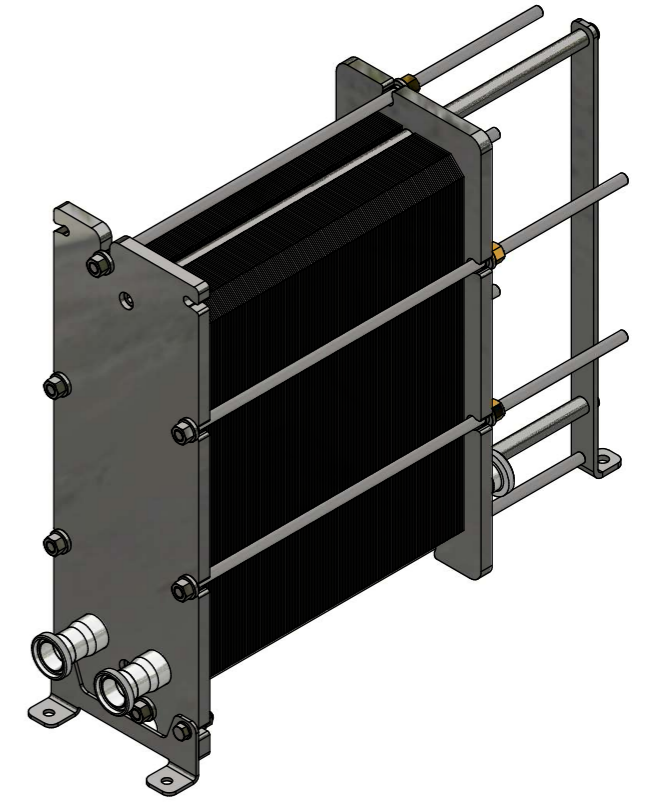

ISOMETRIC VIEW
SCALE 1 : 12

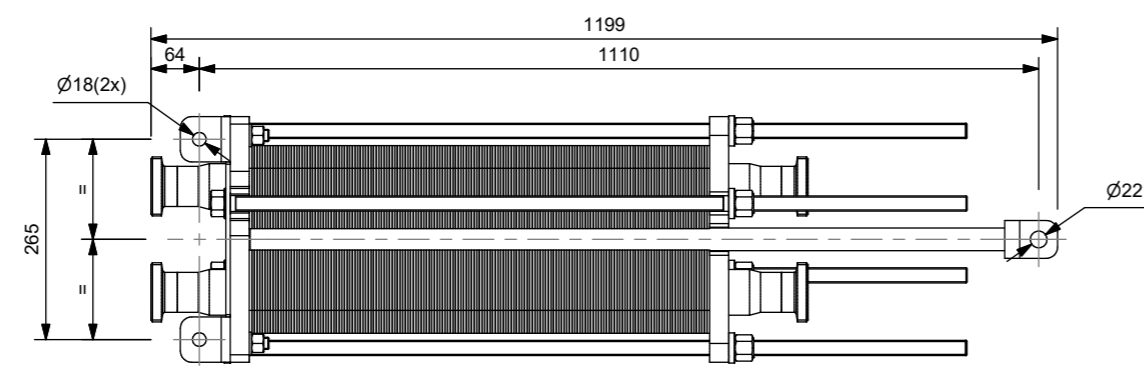

BOTTOM VIEW
SCALE 1 : 10

ITEM	SIZE	TYPE	SERVICE
P1	NW50	MALE THREADED UNION - DIN 11851	Liquid Outlet
P2	NW50	MALE THREADED UNION - DIN 11851	Liquid Inlet
P3	NW50	MALE THREADED UNION - DIN 11851	Liquid Outlet
P4	NW50	MALE THREADED UNION - DIN 11851	Liquid Inlet

NOZZLE SCHEDULE

REVISION	REV	DESCRIPTION	DRAWN	CHECKED	APPROVED	DATE
	A	ISSUED FOR APPROVAL	JD	DDB	DDB	19.11.2024

**AT-6 - 2 PASS HYGIENIC
PLATE AND FRAME HEAT EXCHANGER
GENERAL ARRANGEMENT**

This drawing is subject to return on demand and must not be copied or passed on to any third party; or used directly or indirectly for any other purpose that the design and construction to the order of APEX THERMAL

 A3 SCALE : 1:16	AT-6 - 2 PASS HYGIENIC HEAT EXCHANGER	 APEX THERMAL
SUB CONTRACTOR DWG NO		Sheet of REV
CLIENT DWG NO		Sheet of REV
APEX DWG NO AT-6-2PH-GA-001		Sheet 1 of 1 REV A